



USER MANUAL for digital indicator with relay outputs

type: **PMS-620N**

firmware version: 5.06 or higher



Read the user's manual carefully before starting to use the unit.
Producer reserves the right to implement changes without prior notice.

CONTENTS

1. BASIC REQUIREMENTS AND USER SAFETY	3
2. GENERAL CHARACTERISTICS	4
3. TECHNICAL DATA	4
4. DEVICE INSTALLATION	6
4.1. UNPACKING.....	6
4.2. ASSEMBLY.....	6
4.3. CONNECTION METHOD.....	7
4.4. MAINTENANCE.....	12
5. FRONT PANEL DESCRIPTION	13
6. PRINCIPLE OF OPERATION	14
6.1. MEASUREMENT MODE.....	14
6.2. DETECTION OF THE PEAK VALUES.....	15
6.3. CONTROL OF THE RELAY OUTPUTS.....	16
6.3.1. One threshold mode.....	17
6.3.2. Two thresholds mode.....	18
7. DEVICE PROGRAMMING	19
7.1. PROGRAMMING MENU.....	19
7.2. PARAMETERS EDITION.....	20
7.2.1. Numeric parameters.....	20
7.2.2. Switch parameters ("LIST" type).....	20
7.3. MENU DESCRIPTION.....	21
7.3.1. "rEL1", "rEL2" menu.....	21
7.3.2. "inPt" menu.....	23
7.3.3. "brj" parameter.....	26
7.3.4. "HOLd" menu.....	26
7.3.5. "SECu" menu.....	27
7.3.6. "rS" menu.....	27
7.3.7. "SErv" menu.....	28
7.4. MENU STRUCTURE.....	29
8. THE ALARM LED	31
9. OVER-CURRENT PROTECTION	31
10. DISPLAYED VALUES CALCULATION	31
10.1. ADDITIONAL CALCULATIONS (USED CONVERSION CHARACTERISTIC).....	31
10.1.1. Linear charakteristic.....	32
10.1.2. Square charakteristic.....	32
10.1.3. Square root charakteristic.....	33
10.1.4. User defined charakteristic.....	33
10.2. EXAMPLES OF CALCULATIONS.....	34
11. THE MODBUS PROTOCOL HANDLING	37
11.1. LIST OF REGISTERS.....	37
11.2. TRANSMISION ERRORS DESCRIPTION.....	40
11.3. EXAMPLES OF QUERY/ANSWER FRAMES.....	40
12. DEFAULT AND USER'S SETTINGS LIST	42

Explanation of symbols used in the manual:



- This symbol denotes especially important guidelines concerning the installation and operation of the device. Not complying with the guidelines denoted by this symbol may cause an accident, damage or equipment destruction.

IF THE DEVICE IS NOT USED ACCORDING TO THE MANUAL THE USER IS RESPONSIBLE FOR POSSIBLE DAMAGES.



- This symbol denotes especially important characteristics of the unit. Read any information regarding this symbol carefully

1. BASIC REQUIREMENTS AND USER SAFETY



- **The manufacturer is not responsible for any damages caused by inappropriate installation, not maintaining the proper technical condition and using the unit against its destination.**
- Installation should be conducted by qualified personnel . During installation all available safety requirements should be considered. The fitter is responsible for executing the installation according to this manual, local safety and EMC regulations.
- The unit must be properly set-up, according to the application. Incorrect configuration can cause defective operation, which can lead to unit damage or an accident.
- **If in the case of a defect of unit operation there is a risk of a serious threat to the safety of people or property additional, independent systems and solutions to prevent such a threat must be used.**
- **The unit uses dangerous voltage that can cause a lethal accident. The unit must be switched off and disconnected from the power supply prior to starting installation of troubleshooting (in the case of malfunction).**
- Neighboring and mating equipment must meet the requirements of appropriate standards and regulations concerning safety and be equipped with adequate anti-overvoltage and anti-interference filters.
- **Do not attempt to disassemble, repair or modify the unit yourself. The unit has no user serviceable parts. Units, in which a defect was stated must be disconnected and submitted for repairs at an authorized service center.**



- In order to minimize fire or electric shock hazard, the unit must be protected against atmospheric precipitation and excessive humidity.
- Do not use the unit in areas threatened with excessive shocks, vibrations, dust, humidity, corrosive gasses and oils.
- Do not use the unit in explosion hazard areas.



- Do not use the unit in areas with significant temperature variations, exposed to condensation or icing.
- Do not use the unit in areas exposed to direct sunlight.
- Make sure that the ambient temperature (e.g. inside the control box) does not exceed the recommended values. In such cases forced cooling of the unit must be considered (e.g. by using a ventilator).



The unit is designed for operation in an industrial environment and must not be used in a household environment or similar.

2. GENERAL CHARACTERISTICS

The **PMS-620N** digital indicator is equipped with one measurement input (current input) with user selected range 0-20mA or 4-20mA and a standard resistor protection circuit. Displayed values range can be selected by user, from -999 to 9999, plus decimal point. Additionally the **PMS-620N** allows user to select a conversion characteristic of several kinds: linear, square, square root and user defined – max. 20 points length. The device is equipped with a sensor supply output (non stabilized, 24VDC \pm 3V / 25mA), and one (or two) relay outputs which can be loaded max. 1A/250V. **PMS-620N/E** version of the unit is not equipped with relay outputs. The digital indicator can be ordered in two power supply versions: 230VAC and 24VDC.

The device has 4 buttons being used for main presets programming. To get high protection level, the keyboard is mounted under transparent cover. To allow user to change presets without opening the cover, an IR sensor is mounted. Remote controller keyboard is equivalent to the device keyboard (Note, that remote controller is not a part of the **PMS-620N** set. It is an additional equipment.).

PMS-620N can be used for controlling and regulation of processes need proportional and threshold control like: temperature processes (heating or cooling), valves controlling or other.

3. TECHNICAL DATA

Power supply voltage (depending on version)	230V AC \pm 10%, 50 \div 60 Hz 24V DC \pm 15%, (not separated)
External fuse (required)	T - type, max. 2 A
Power consumption	max. 2,6 VA @ 230V AC max. 4,5 VA @ 24V DC
Measurement input	
current range:	0 \div 20 mA, 4 \div 20 mA overload protected, maximum input current about 40 mA
measurement input resistance:	50 Ω
accepted prolonged input overload:	20%

Outputs

relay (optional): 1 or 2 NO, 1A/250V AC ($\cos \varphi = 1$),
not available in **PMS-620N/E** version
 sensor power supply U_S : not stabilized, not separated from measuring inputs,
in 230V AC version:
 $U_S = 24V \text{ DC} \pm 3V / \text{max. } 25 \text{ mA}$;
 in 24V DC version:
 $U_S = U_{PS} / \text{max. } 100 \text{ mA}$, $R_{int.} = 30 \Omega$,
 (where U_{PS} - device power supply, $R_{int.}$ - internal
 resistance for sensor power supply output);

Display range -999 ÷ 9999, plus decimal point

Current measurement accuracy $\pm 0,25\% \pm$ one digit

Communication interface RS 485, 8N1 / Modbus RTU, not separated

Baud rate 1200 bit/s ÷ 115200 bit/s

Display LED, 4 digit, 20mm height, red

Protection level IP 65

Housing type wall mounted

Housing material ABS + fibreglass

Housing dimensions

without glands: 110 x 80 x 67 mm

with glands: 110 x 105 x 67 mm

Operating temperature 0°C to $+50^{\circ}\text{C}$

Storage temperature -10°C to $+70^{\circ}\text{C}$

Humidity 5 to 90% no condensation

Altitude up to 2000 meters above sea level

Screws tightening max. torque 0,5 Nm

Max. connection leads diameter 2,5 mm²

Safety requirements according to:

PN-EN 61010-1:1999 + PN-EN 61010-1/A2:1999

installation category: II

pollution degree: 2

voltage in relation to ground: 300V AC

insulation resistance: $>20M\Omega$

insulation strength between power supply and input/output

terminal: 1min. @ 2300V

insulation strength between relays terminal: 1min. @ 1350V

EMC PN-EN 61326:2003



This is a class A unit. In housing or a similar area it can cause radio frequency interference. In such cases the user can be requested to use appropriate preventive measures.

4. DEVICE INSTALLATION

The unit has been designed and manufactured in a way assuring a high level of user safety and resistance to interference occurring in a typical industrial environment. In order to take full advantage of these characteristics installation of the unit must be conducted correctly and according to the local regulations.



- Read the basic safety requirements on page 3 prior to starting the installation.
- Ensure that the power supply network voltage corresponds to the nominal voltage stated on the unit's identification label.
- The load must correspond to the requirements listed in the technical data.
- All installation works must be conducted with a disconnected power supply.
- Protecting the power supply clamps against unauthorized persons must be taken into consideration.

4.1. UNPACKING

After removing the unit from the protective packaging, check for transportation damage. Any transportation damage must be immediately reported to the carrier. Also, write down the unit serial number on the housing and report the damage to the manufacturer.

Attached with the unit please find:

- warranty,
- user's manual for **PMS-620N** unit (device)

4.2. ASSEMBLY



- Disconnect the power supply prior to starting assembly.
- Check the correctness of the performed connections prior to switching the unit on.

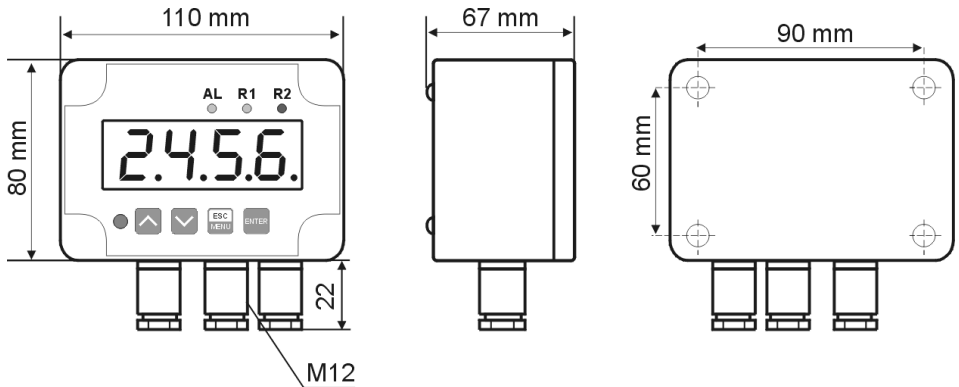

Figure 4.1. Device and assembly dimensions



To install device on the wall, a pinholes should be made. Figure 4.1 presents dimensions of the device and distances between holes. The back side of the device has four mounting holes. This part of the case should be mounted to a wall by screws.

4.3. CONNECTION METHOD

Caution



- Installation should be conducted by qualified personnel . During installation all available safety requirements should be considered. The fitter is responsible for executing the installation according to this manual, local safety and EMC regulations.
- The unit is not equipped with an internal fuse or power supply circuit breaker. Because of this an external time-delay cut-out fuse with minimal possible nominal current value must be used (recommended bipolar, max. 2A) and a power supply circuit-breaker located near the unit. In the case of using a monopolar fuse it must be mounted on the phase cable (L).
- The power supply network cable diameter must be selected in such a way that in the case of a short circuit of the cable from the side of the unit the cable shall be protected against destruction with an electrical installation fuse.
- Wiring must meet appropriate standards and local regulations and laws.
- In order to secure against accidental short circuit the connection cables must be terminated with appropriate insulated cable tips.
- Tighten the clamping screws. The recommended tightening torque is 0.5 Nm. Loose screws can cause fire or defective operation. Over tightening can lead to damaging the connections inside the units and breaking the thread.



- In the case of the unit being fitted with separable clamps they should be inserted into appropriate connectors in the unit, even if they are not used for any connections.
- Unused clamps (marked as n.c.) must not be used for connecting any connecting cables (e.g. as bridges), because this can cause damage to the equipment or electric shock.
- If the unit is equipped with housing, covers and sealing packing, protecting against water intrusion, pay special attention to their correct tightening or clamping. In the case of any doubt consider using additional preventive measures (covers, roofing, seals, etc.). Carelessly executed assembly can increase the risk of electric shock.
- After the installation is completed do not touch the unit's connections when it is switched on, because it carries the risk of electrical shock.

Due to possible significant interference in industrial installations appropriate measures assuring correct operation of the unit must be applied. To avoid the unit of improper indications keep recomendations listed below.

- Avoid common (parallel) leading of signal cables and transmission cables together with power supply cables and cables controlling induction loads (e.g. contactors). Such cables should cross at a right angle.
- Contactor coils and induction loads should be equipped with anti-interference protection systems, e.g. RC-type.
- Use of screened signal cables is recommended. Signal cable screens should be connected to the earthing only at one of the ends of the screened cable.
- In the case of magnetically induced interference the use of twisted couples of signal cables (so-called "spirals") is recommended. The spiral (best if shielded) must be used with RS-485 serial transmission connections.
- In the case of interference from the power supply side the use of appropriate anti-interference filters is recommended. Bear in mind that the connection between the filter and the unit should be as short as possible and the metal housing of the filter must be connected to the earthing with largest possible surface. The cables connected to the filter output must not run in parallel with cables with interference (e.g. circuits controlling relays or contactors).

Connection of the power supply, and the measurement and controlling signals should be made by screw connectors mounted inside the housing (Figure 4.2 - 4.6).

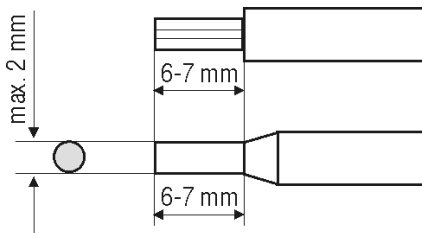

Figure 4.2. Method of cable insulation replacing and cable terminals

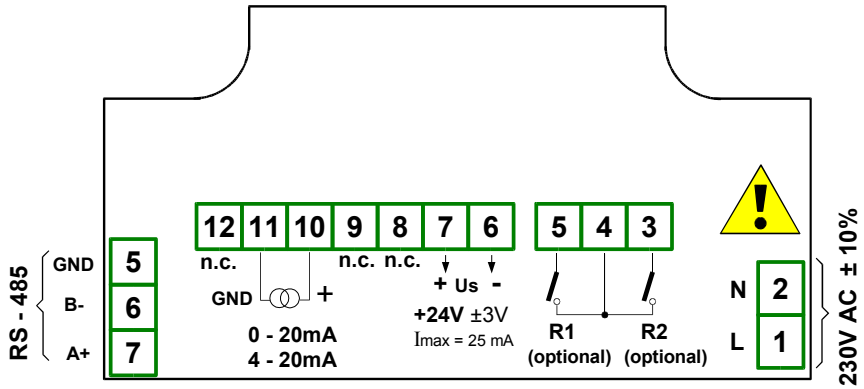

Figure 4.3. Terminals description (230V AC version)

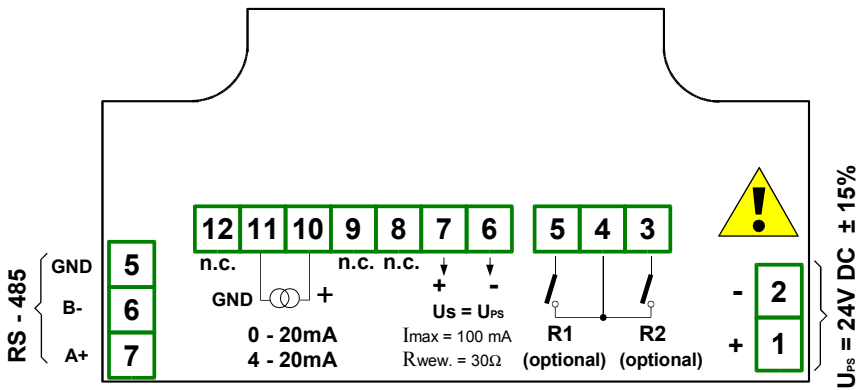

Figure 4.4. Terminals description (24V DC version)

a)

b)

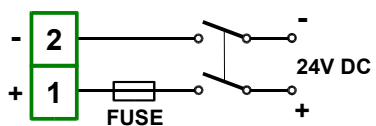
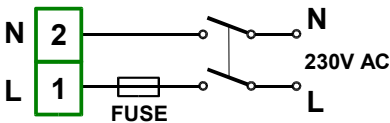

Figure 4.5. Connection of power supply:
a) for 230V AC version, b) for 24V DC version



All connections must be made while power supply is disconnected !

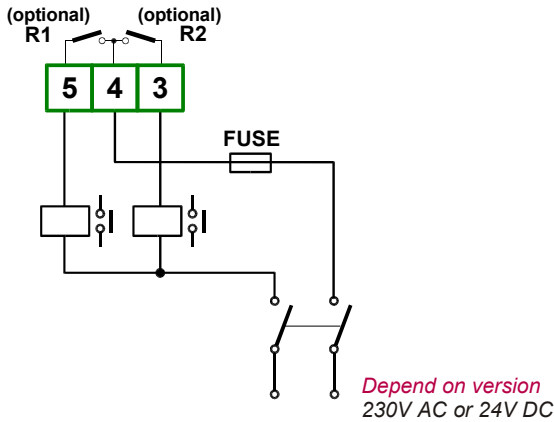

Figure 4.6. Connection of relays

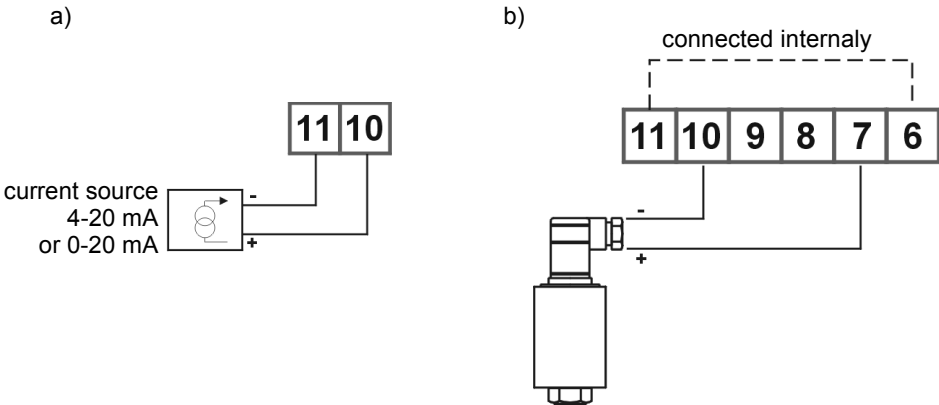

Figure 4.7. Connections of 2-wire sensor:
a) active, b) passive (needs additional supply)



PMS-620N digital indicator has no galvanic separation between measurement input and RS-485 interface. If serial connection of multiple units is made or serial connection with other device, without galvanic separation of RS-485 interface, is made then RS-485 interface separators must to be used certainly (Figure 4.8,4.9). If RS-485 interfaces are isolated or not used then the separators are not necessary.

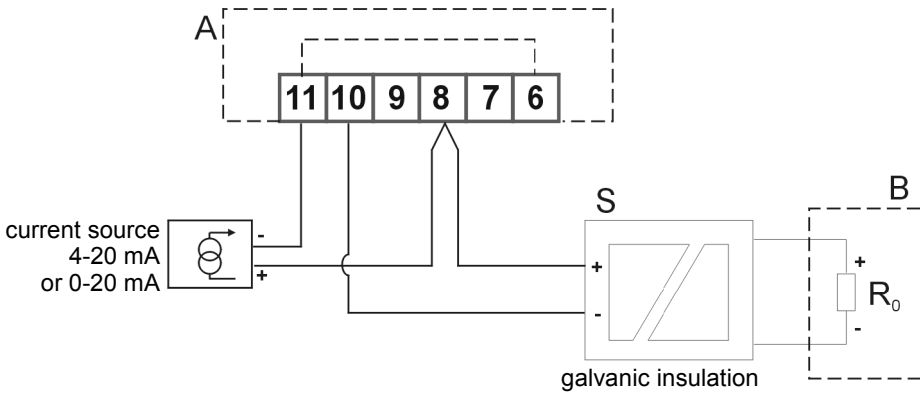

Figure 4.8. Serial connection of active 2-wire sensor with PMS-620N unit and other current measurement device (e.g. PLC controller).

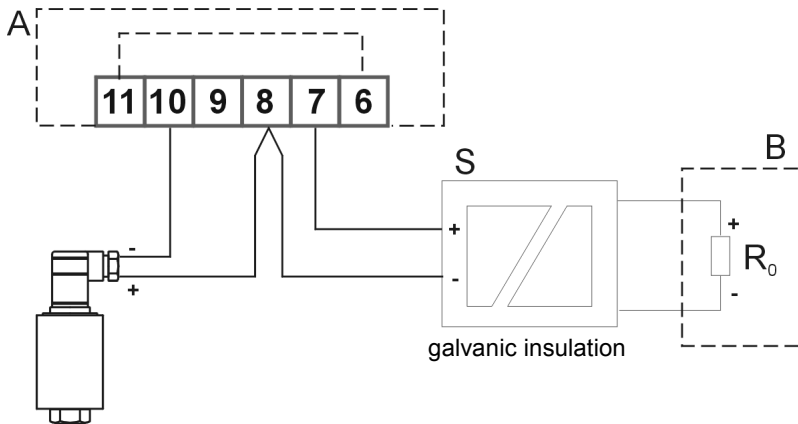

Figure 4.9. Serial connection of passive 2-wire sensor with PMS-620N unit and other current measurement device (e.g. PLC controller).



If device **B** (Figure 4.8, 4.9) is equipped with galvanic separated input or if different potentials between **A** and **B** devices signal grounds are allowed (e.g. if RS-485 interface is separated or unused), current loop can be closed without separator **S**.

Calculation of maximal allowable resistance of separator's input

Maximal resistance of the input ($R_{S \max.}$) and wires ($R_{p \max.}$) are calculated for circuit from Figure 4.9. Used symbols are described below.

- $U_{cz \min.}$ - minimal sensor supply voltage (given in technical data of sensor),
- $I_{\max.} = 20 \text{ mA}$ - maximal current of current loop,
- U_g - voltage drop on galvanic separator input (constant for 4-20 mA range of current),
- 24V - **PMS-620N** sensor supply output voltage,
- $R_{wew.} = 50 \Omega$ - **PMS-620N** measurement input resistance,
- $R_z = 10 \Omega$ - **PMS-620N** internal resistance of sensor supply output

$$R_{S \max.} + R_{p \max.} = \frac{24 V - U_{cz \min.} - U_g - R_{wew.} - R_z}{I_{\max}}$$

Let $U_{cz \min.} = 12V$ and $U_g = 5V$ then:

$$R_{S \max.} + R_{p \max.} = \frac{24 - 12 - 3,5}{0,02} - 50 - 10 = 290 \Omega$$

If current loop is closed without the separator **S**, then sum of measurement input resistance ($R_{0 \max.}$) of device **B** (Figure 4.9) and connections resistance ($R_{p \max.}$) should be not greater than result of given below formula:

$$R_{0 \max.} + R_{p \max.} = \frac{24 V - U_{cz \min.}}{I_{\max}} - R_{wew.} - R_z$$

For example, if $U_{cz \min.} = 12V$ then:

$$R_{0 \max.} + R_{p \max.} = \frac{24 - 12}{0,02} - 50 - 10 = 540 \Omega$$

4.4. MAINTENANCE

The unit does not have any internal replaceable or adjustable components available to the user. Pay attention to the ambient temperature in the room where the unit is operating. Excessively high temperatures cause faster ageing of the internal components and shorten the fault-free time of unit operation.

In cases where the unit gets dirty do not clean with solvents. For cleaning use warm water with small amount of detergent or in the case of more significant contamination ethyl or isopropyl alcohol.



Using any other agents can cause permanent damage to the housing.

5. FRONT PANEL DESCRIPTION

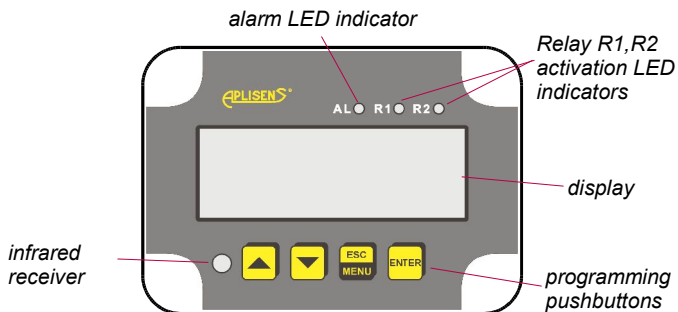

 LEDs named „R” indicates exceeding of the thresholds set in menus connected to relay outputs, even if some relays are not available (see „rEL1”, „rEL2” menu).

Symbols and functions of pushbuttons



Symbol used in the manual: **[ESC/MENU]**

Functions:

- Enter to main menu (press and hold by at least 2 sec.)
- Exit the current level and Enter to previous menu (or measure mode)
- Cancel the changes made in parameter being edited



Symbol used in the manual: **[ENTER]**

Functions:

- Start to edit the parameter
- Enter to the sub-menu,
- Confirmation of changes made in parameter being edited



Symbol used in the manual: **[^] [v]**

Functions:

- Change of the present menu,
- Modification of the parameter value,
- Change of the display mode.

6. PRINCIPLE OF OPERATION

After turning the power supply on, device ID and software version are showed on the display, next the controller goes to the measurement mode.

6.1. MEASUREMENT MODE

In the measure mode, the measurement results, converted over selected characteristic, are displayed on the display. The measurement range equal to the nominal range is called: **nominal measurement range**, and the measurement range equal to the extended nominal range is called: **permissible measurement range** (Figure 6.1, 6.2).

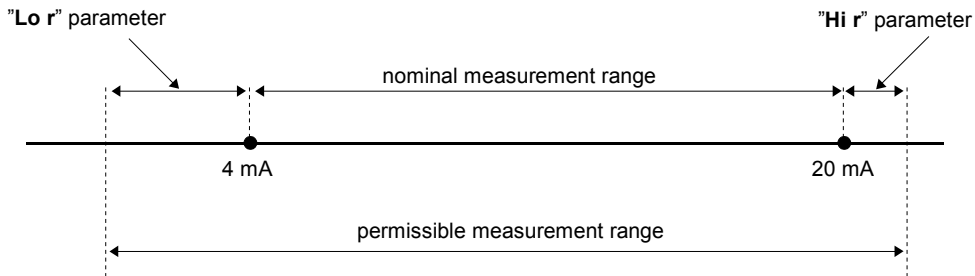

Figure 6.1. Definitions of measurement ranges in mode 4 ÷ 20mA

If the result of measurement exceeds the **permissible measurement range**, warning **"-Hi-"** or **"-Lo-"** is displayed rather than input signal, depends on exceeded value (see description of **"Lo r"** i **"Hi r"** parameters, paragraph **"inPt" menu**).

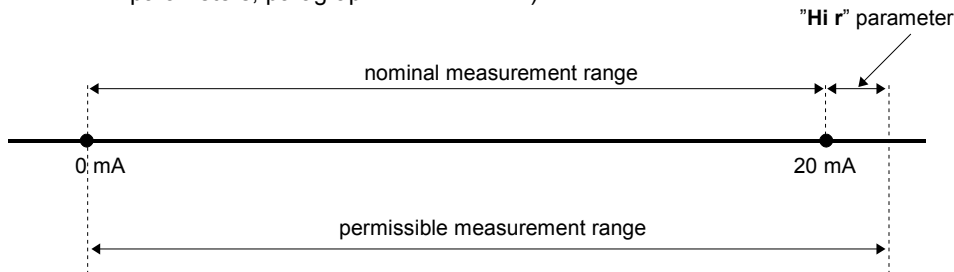

Figure 6.2. Definitions of measurement ranges in mode 0 ÷ 20mA



If the measurement value do not exceeds **permissible measurement range** but displayed value exceeds range -999 ÷ 9999, the warning **"-Ov-"** is displayed rather than the calculated result.

In the measurement mode user can check main thresholds values. After pressing [^] or [v] button, name of the threshold ("rEL1" or "rEL2") and his value will be displayed on the display in alternating mode. If [^] or [v] will be pressed in 5 sec again, the next threshold will be displayed, else the device comes back to the measurement mode. If a **free access** is enabled (parameter "Acce" = on), user can change the value of particular threshold pressing button [ENTER] (see: **PARAMETERS EDITION**).

Input type, range of displaying values, characteristic of conversion, decimal point position and measure filtering ratio, are user configurable parameters. All accessible parameters can be changed by entering the menu (see: **DEVICE PROGRAMMING**). Use the local keyboard or the remote controller to do it. (Note: all parameters can be remote changed via RS-485 interface).

i Configuration of the device (via menu or RS 485 interface) **do not stops measures**.

6.2. DETECTION OF THE PEAK VALUES

The controller is equipped with peaks detection function. It can detect a peaks of the input signal and display their values. Presets connected with this function are placed in "HOLd" menu (see description of "HOLd" menu). The detection of the peak can be done if the measured signal raises and drops of value at least equal to parameter "PEA". Detected peaks are displayed during the time defined by parameter "timE". If a new peak will be detected while one is displayed, this new peak will be displayed and display time counter will be cleared (Figure 6.3). If no peaks are detected while time "timE" elapses, device starts to show the current value of input signal again.

The relays/LEDs (in PMS-620N/E version LEDs only) can be controlled depend on the current value of input signal or the peak value (see "HOLd" menu).

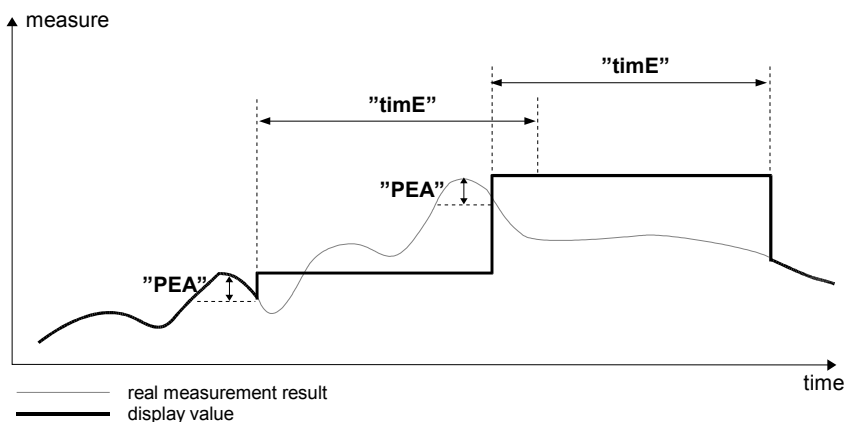

Figure 6.3. Process of peaks detection

6.3. CONTROL OF THE RELAY OUTPUTS

The control of the object (measured signal) is realized via relay outputs. Front panel LEDs named „R” indicates the state of particular relay output.

i If device is not equipped with one or more relay outputs, menus referred to this relays are available, but apply to LED indicators only. In such case LEDs indicates exceeding of particular thresholds.

Modes of the control can be changed depend on the values of parameters “SEtP”, “SEt2”, “HYSt”, “modE”, “t on”, “toFF”, “unit” and “AL”. Depend on “modE” parameter, relays/LEDs can be not used or controlled over one or two thresholds values.

If one threshold is used (Figure 6.4) the relay/LED can be turned on (“modE” = “on”) or off (“modE” = “off”) when the input signal value is contained in **zone A**. If two thresholds are used (Figure 6.5) the relay/LED will be turned on when value of input signal is contained in **zone A** (“modE” = “in”) or **zone B** (“modE” = “out”) and turned off if the signal is contained in the second one.

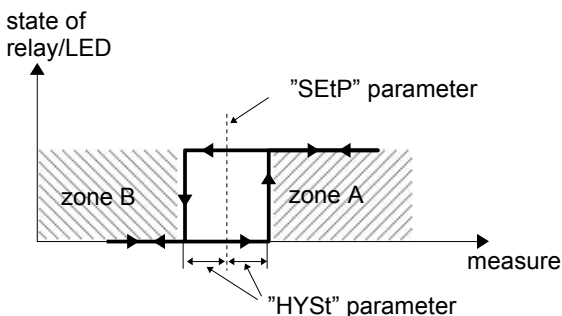

Figure 6.4. One threshold control of the relay outputs and LEDs R1, R2

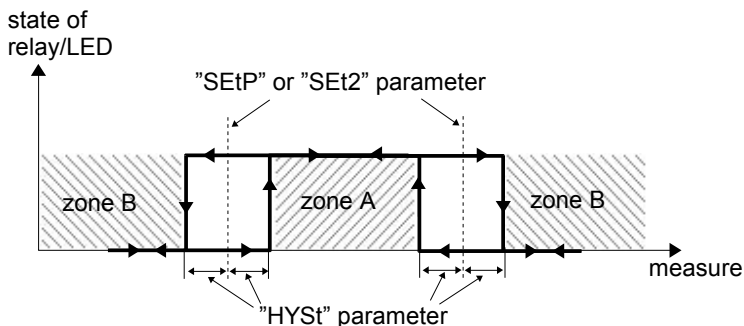
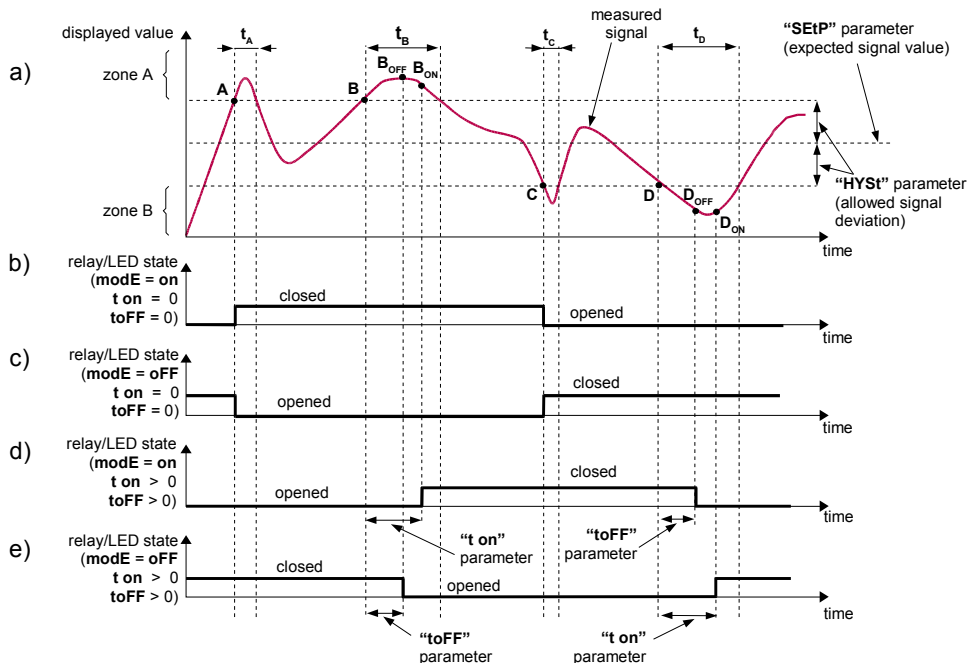

Figure 6.5. Two thresholds control of the relay outputs and LEDs R1, R2

i The relay outputs and LEDs R1, R2 can be controlled depend on both - the current value and the peak value (when peak detection is active) of the input signal.

6.3.1. One threshold mode

Figure 6.6 presents the principle of relay outputs (and LEDs R1, R2) operation for one threshold mode, and an example values of other parameters.



Description:

- A, B, C, D - points where measured signal exceeds border values (expected value \pm allowed deviation)
- B_{ON}, B_{OFF}, D_{ON}, D_{OFF} - relays/LEDs state changes moments: (for "t on" > 0, "toFF" > 0)
- t_A, t_B, t_C, t_D - time periods while input signal is in zone A or zone B

Figure 6.6. Principle of LED/relay output operation for one threshold mode

Parameter "SetP" sets a **threshold** of the relay/LED, and parameter "Hyst" sets a **hysteresis** of the relay/LED (Figure 6.6 a). The relay/LED can change his state **only** when input value exceeds (over or under) **border value** and t_A, t_B, t_C, t_D times (Figure 6.6) are bigger than the time defined by parameters "t on", "toFF" and "unit". **Border values** means values equal **threshold+hysteresis** and **threshold-hysteresis** respectively.

If "t on" and "toFF" parameters are set to "0", then the relay/LED state will be changed **as soon** as input value exceeds any of the **border values** (see points A and C, Figure 6.6 a, b, c).

If values of "t on" or/and "toFF" are positive, then relay/LED state will be turned on if the input value exceeds the **border values** and stay bigger (or lower) during at least "t on" (see points B_{ON}, D_{ON}, Figure 6.6 a, d, e). Similarly, the relay/LED will be turned off if time "toFF" elapse since the input signal value exceeds any of the **border values** (see points B_{OFF}, D_{OFF}, Figure 6.6 a, d, e).

If t_A , t_B , t_C or t_D (when input signal stay in **zone A** or **zone B**) are lower than parameters “**t on**” or “**toFF**”, the relay/LED will not change his state (see points A and C, Figure 6.6 a, d, e).

The state of LED/relay output while the input value exceeds the **border values** (points A, B, C, D) is described by parameter “**modE**”. The relay/LED can be turned on (“**modE**” = “**on**”), or turned off (“**modE**” = “**oFF**”) when input signal value is contained in **zone A** (Figure 6.6 a).

The parameter “**AL**” allow user to set the LED/relay output behavior in critical situations (e. g. Input values exceeds **permissible measurement range**). User can select that the relays/LEDs will be turned on, turned off, or not changed in critical situations.

All parameters connected with LEDs/relay outputs are described in paragraph “**rEL1**”, “**rEL2**” menu.

6.3.2. Two thresholds mode

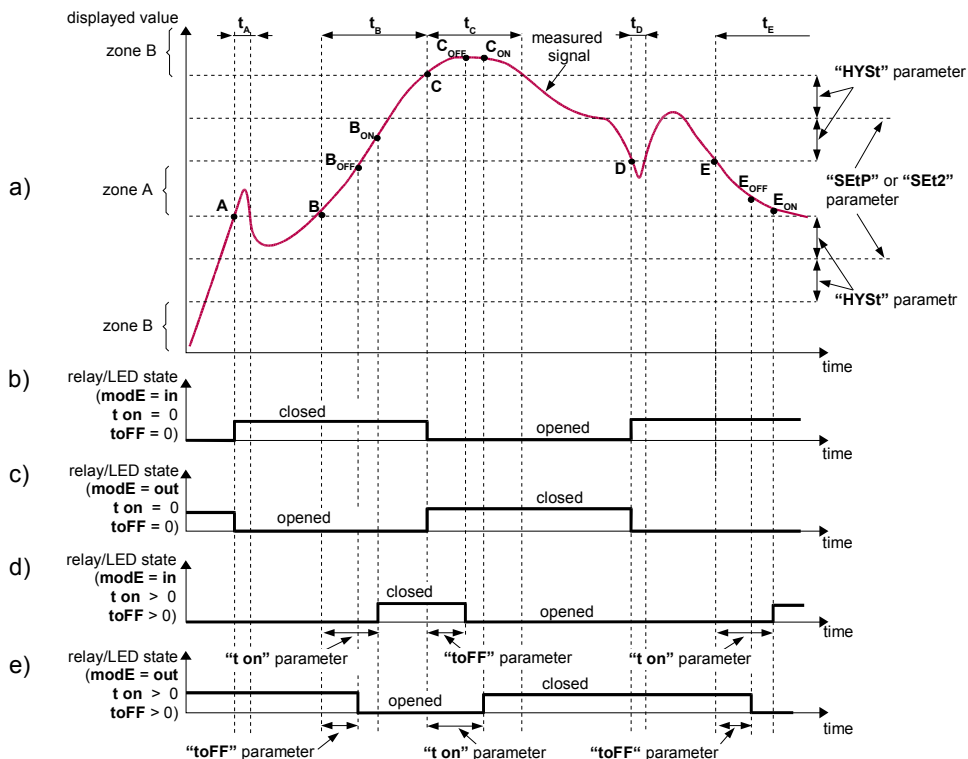

Description:

- A, B, C, D, E - points where measured signal exceeds border values (expected value \pm allowed deviation)
- B_{ON} , B_{OFF} , C_{ON} , C_{OFF} , E_{ON} , E_{OFF} - relays/LEDs state changes moments: (for “**t on**” > 0, “**toFF**” > 0)
- t_A , t_B , t_C , t_D , t_E - time periods while input signal is in zone A or zone B

Figure 6.7. Principle of LED/relay output operation for two thresholds mode

Figure 6.7 presents the principle of LEDs/relay outputs operation for two thresholds mode, and an example values of other parameters. In this mode parameter **“Set2”** is accessible in common with **“SetP”**, this parameter describes a second threshold of the LED/relay output. The parameters **“HYSt”**, **“modE”**, **“t on”**, **“toFF”**, **“unit”** and **“AL”** are connected with both **“SetP”** and **“Set2”** thresholds. While the controlling process, the LED/relay output changes his state depends of both **“SetP”** and **“Set2”** thresholds in similar way as it was described in one threshold mode.

If two threshold mode is used, **“modE”** parameter defines state of the LED/relay output when the input value occurs in a particular zone defined by **border values** of both **thresholds**. The relay/LED can be turned on if the input value is contained in **zone A** (**“modE”** = **“in”**) or **zone B** (**“modE”** = **“out”**) and turned off if it is contained in the second one (Figure 6.7).



The sequence of thresholds **“SetP”** and **“Set2”** can be set in any order, due to the control of LEDs/relay outputs is done depend on difference between thresholds values (**zone A**) and outside of threshold values (**zone B**).

7. DEVICE PROGRAMMING

The device menu allow user to set all parameters connected to operation of measurement input, control modes, critical situations behavior, communication via RS-485 and access settings. The meaning of the particular parameters is described in paragraph **MENU DESCRIPTION**.

Some of the parameters can be accesed without menu entering (quick view mode). After pressing **[^]** or **[v]** button, name of the threshold (**“rEL1”** or **“rEL2”**) and his value will be displayed on the display in alternating mode. If **[^]** or **[v]** will be pressed in 5 sec again, the next threshold will be displayed, else the device comes back to the measurement mode. If a **free access** is enabled (parameter **“AccE”** = on), user can change the value of particular threshold pressing button **[ENTER]** (see: **PARAMETERS EDITION**).



If particular parameter has been changed and confirmed in quick view mode, its new value is displayed in alternating mode with parameter name by few seconds. Confirmed changes may be checked or user can switch viewed parameter pressing **[^]** or **[v]** button.

7.1. PROGRAMMING MENU

To enter main menu (being in the measurement mode) operator must to press and hold at least 2 sec. **[ESC/MENU]** button.

If the user password is defined (see parameter **“Scod”**, menu **“SECU”**), operator have to enter correct one before proceeding to menu options . Entering of the passwords is similar to the edition of numeric parameters (see: **PARAMETERS EDITION**), however presently editing digit is showed only on the display, other digits are replaced by **“-”** sign.

After entering of last digit of the password first menu position will be displayed (if the password is correct) or warning "Err" in other case.



Pay attention when device parameters are being changed. If it is possible, turn off controlled installation (machine).

Functions of the buttons while sub-menu and parameters choice:



Selection of sub-menu or parameter for editing. Name of selected item (sub-menu or parameter) is displayed.



Operation of **[ENTER]** button depend on present menu position:

- if the name of some sub-menu is displayed - enter this sub-menu; name of the first parameter (or next level sub-menu) is displayed,
- if the name of some parameter is displayed - enter the edition of this parameter; present value of the parameter is displayed,



[ESC/MENU] button allow user to exit present menu level and goes to upper level menu (or measurement mode).



After about 1 min since last use of the buttons, device exits the menu mode and returns to the measurement mode (only if no parameters are in editing mode).

7.2. PARAMETERS EDITION

To start edition of any parameter user should select name of desired one using **[^]** **[v]** buttons and then **[ENTER]**.

7.2.1. Numeric parameters

Numeric parameters constitute a series of digits that form a number in decimal format. Entering a new parameter value consists of changing the values of selected digits within the allowable range (using the **[^]**, **[v]** keys). Some numeric parameters can take negative values). In such cases the "-" mark can be selected on the first decimal position of the parameter.

7.2.2. Switch parameters ("LIST" type)

Switch parameters can be described as a sets of values (a lists) out of which only one of the options available on the list can be selected for the given parameter. Options of switching parameter are selected using **[^]**, **[v]** keys.

Functions of buttons when editing numeric and switching parameters:



Change of current (flashing) digit value while editing numeric parameter, or value of switch parameter.



If numerical parameter is being edited, a short press of **[ENTER]** button change edited position. A long press of **[ENTER]** button (at least 2 sec.) causes of display a "SEt?" ask, which allow user to make sure if change of the parameter value is correct. If switch parameter is being edited, a short press of **[ENTER]** button causes of display a "SEt?" ask. When **[ENTER]** button is pressed again (while "SEt?" is displayed) the new value of the parameter is stored in EEPROM memory.



Pressing this button operator can cancel the changes done up to now (if they were not approved by **[ENTER]** button after the "SEt?" ask) and come back to menu

7.3. MENU DESCRIPTION

"- - - -" Password cheking. If any password different from „0000” is set, than every enter to main menu follows the entering of password. If entered password is correct first menu position will be displayed else warning "Err", and unic returns to measurement mode.

7.3.1. "rEL1", "rEL2" menu

This menu contains options of configuration of operation of relays R1 and R2. Principles of the relays operation is described in paragraph **CONTROL OF THE RELAY OUTPUTS**.



- The relay output can be controlled by both – the present value and the peak value of input signal (if peak detection function is active).
- If device is not equipped with one or more relay outputs, menus referred to this relays are available, but apply to LED indicators only. In such case LEDs indicates exceeding of particular thresholds.

"SEtP" - first threshold of the relay (range -999 ÷ 9999). Negative values can be input by selecting a "-" sign on first digit (to change value use **[^]** and **[v]** buttons). **Threshold is the medium value of relay/LED hysteresis.**

"SEt2" - second threshold of the relay (range -999 ÷ 9999). Negative values can be input by selecting a "-" sign on first digit (to change value use **[^]** and **[v]** buttons). This threshold is accessible when "mode" parameter is set to „in" or „out" value. **Threshold is the medium value of relay/LED hysteresis.**

"HYSt" - Hysteresis of relay (range 0 -999). Full hysteresis of the relay is equal to 2x "HYSt" parameter. The relay/LED state can change when an input signal is out of **threshold-hysteresis** to **threshold+hysteresis** zone.



Presented parameters should be set to ensure that **SEtP + HYSt**, **SEt2 + HYSt**, **SEtP - HYSt** and **SEt2 - HYSt** do not exceeds the measure range (“Lo C” i “Hi C” paramaters). Additionally, in two threshold mode (“mode”= „in” or „out”), the hysteresis for both thresholds must not cover each other (in other case relay/LED can't change his state).

“mode” - relay/LED operation mode:

“noAC” - the relay/LED is not active (permanent turned off)

“on” - one threshold mode, the relay/LED is turned **ON** when input signal exceeds **SEtP + HYSt** value, and is turned off back when the input signal became lower than **SEtP – HYSt**,

“oFF” - one threshold mode, the relay/LED is turned **OFF** when input signal exceeds **SEtP + HYSt** value, and is turned on back when the input signal became lower than **SEtP – HYSt**,

“in” - two threshold mode, the relay/LED is turned **ON** when the input signal is bigger than “**lower threshold + HYSt**” and lower than “**bigger threshold – HYSt**”, and turned off when the input signal is contained in the second zone. The **bigger threshold** means bigger one of “**SEtP**” and “**SEt2**” thresholds, the **lower threshold** means lower one of “**SEtP**” and “**SEt2**” thresholds.

“out” - two threshold mode, relay/LED is turned **OFF** when the input value is bigger than “**bigger threshold + HYSt**” and lower than “**lower threshold – HYSt**”, and turned on when the input signal is contained in the second zone. The **bigger threshold** means bigger one of “**SEtP**” and “**SEt2**” thresholds, the **lower threshold** means lower one of “**SEtP**” and “**SEt2**” thresholds.

“modb” - the relay/LED is controlled via RS-485 interface, independently on the input signal.



- **LEDs light when relays are closed**, independently of relays' mode.
- When power supply decay, unit do not store relays/LED state selected by RS 485 interface.

“t on” - turn on delay time, the relay/LED is turned on with delay equal “t on” if the input value exceeds appropriate **border value** (defined with **threshold** and **hysteresis**), at least “t on” time. “t on” range 0 ÷ 99.9, defined with 0.1 sec. resolution. Unit of this parameter is set by “unit” parameter.

“toFF” - turn off delay time, the relay/LED is turned off with delay equal “toFF” if the input value exceeds appropriate **border value** (defined with **threshold** and **hysteresis**), at least “toFF” time. “toFF” range 0 ÷ 99.9, defined with 0.1 sec. resolution. Unit of this parameter is set by “unit” parameter.



If time when the input signal exceeds some border value is shorter than “**t on**” or “**toFF**” time, the relay/LED do not change his state (see paragraph: **CONTROL OF THE RELAY OUTPUTS**).

“**unit**” - unit of time for “**t on**” i “**toFF**” parameters. Can be set on one of two values:

“**min**” - minutes,

“**sec**” - sconds.

“**AL**” - This parameter defines the relay/LED reaction when some critical situations occurs:

“**noCH**” - relay/LED do not change his state,

“**on**” - relay/LED will be turned on,

“**oFF**” - relay/LED will be turned off.

If parameter “**modE**” is set to “**on**” or “**oFF**” the “critical situation” means that **AL** LED is turned on.

If parameter “**modE**” is set to “**modb**”, the “critical situation” means communication delay (when no data is received) longer than “**mbtO**” parameter (see description: “**rS**” *menu*).



- If option “**noCH**” is selected for “**AL**” parameter, behavior of the relay/LED may depend on “**FiLt**” parameter in some cases. If “**FiLt**” is set to big value and the input current drops, result value of the measure will change slow, causes of turning on or off relay/LED due to thresholds values. The critical situation is slowly detected, so it is not possible to predict the relay/LED state in that situations.
- If parameter „**AL**” = „**on**”, the relay/LED will be turned on in the critical situations, even if his parameter “**modE**” = “**noAC**”.

7.3.2. “inPt” menu

This menu presets the measurement input:

“**tYPE**” - type of the input / sensor. This parameter can be set to values:

“**0-20**”, “**4-20**” - current inputs of 0÷20mA or 4÷20mA of measurement range respectively. Displayed values are defined by parameters “**Lo C**”, “**Hi C**” (or by user defined characteristic points) and parameter “**Pnt**”.

“**CHAR**” - this option presets type of the conversion characteristic, and can be set to

“**Lin**” - linear

“**Sqr**” - square

“**Sqrt**” - square root

} When one of those characteristics is chosen display range is defined by “**Lo C**” and “**Hi C**”.

“USER” User defined characteristic. Maximal length 20 points. Every point is defined by user. Adding, Editing and Deleting of points is done by options **„AddP”**, **„EdtP”**, **„dELP”** (**„InPt”** menu) respectively.



If user defined characteristic is selected, and if number of defined points is lower than 2 then warning **“Errc”** is displayed in measurement mode.

The process of displayed result calculation is described in details in **DISPLAY VALUES CALCULATION** paragraph.

“Filt” - this parameter sets filtration rate. It can be set to values from 0 (no filtration) to 5 (strongest filtration – time window about 2 sec).

“Pnt” - decimal point position. It can be set to one of:

“ 0”, “ 0.0”, “ 0.00”, “0.000”

Decimal point position is changed by **[^]**, **[v]** buttons.

“Lo C” These parameters describe the values displayed for minimum and maximum input current. If input type is set to 4-20 mA (0-20mA) **“Lo C”** parameter defines the value displayed when input current is equal 4 mA (0mA), and **“Hi C”** parameter defines the value displayed for 20 mA of input current. Available range for these parameters: -999 ÷ 9999. Negative values can be set by entering **“-”** sign on the first position (by use of **[^]**, **[v]** buttons).



If user defined characteristic is selected (parameter **“CHAR”** = **“USER”**) the parameters **„Lo C”** and **„Hi C”** are not available for modification, due to their values are calculated from defined characteristic.

“AddP” - This menu allow user to add single point to the user defined characteristic. After selection of this option device waits for **„X”** and **„Y”** coordinates of new point. Modification of the coordinates is done accordingly to numerical parameters edition. Coordinate **„X”** defines the percentage ratio of input current to selected current range. The **„X”** range: -99,9 ÷ 199,9. Coordinate **„Y”** defines displayed value for particular **„X”** value. The **„Y”** value can be changed in range: -999 ÷ 9999, decimal point position depend on **„Pnt”** parameter (menu **“inPt”**).



- User can not enter two points with the same value of **„X”** coordinate. If user tries to do it, **“Err”** warning is displayed. To modify any defined point use **“EdtP”** option.
- To distinguish **„X”** and **„Y”** coordinates, if **„X”** coordinate is displayed an additional decimal point on utmost right position is displayed.
- If user defined characteristic is selected, and if number of defined points is lower than 2 then warning **“Errc”** is displayed in measurement mode.

“dELP” - this option allows user to delete any of the points of the user defined characteristic. After selection current number of points of the user defined characteristic is displayed for about aprox. 1,5 sec. After that device waits for selection of point being deleted (by **[^]**, **[v]** buttons). The short pressing of **[ENTER]** button causes by switching between **X** and **Y** value of the displayed point. The long press (press and hold at least 2 sec) of **[ENTER]** button causes by displaying „**dEL?**” ask. If **[ENTER]** button is pressed again, current point is deleted and new updated number of points of the user defined characteristic is displayed.

“EdtP” - this option allows user to modify of particular point of the user defined characteristic. After selection current number of points of the user defined characteristic is displayed for about aprox. 1,5 sec. After that device waits for selection of point being edited (by **[^]**, **[v]** buttons). The short pressing of **[ENTER]** button causes by switching between **X** and **Y** value of the displayed point. The long press (press and hold at least 2 sec) of **[ENTER]** button causes by entering to edit the selected coordinate of the point. Modification of the coordinates is done accordingly to numerical parameters edition.



“AddP”, **“dELP”** and **“EdtP”** options are available only if the user defined characteristic is used (it means when parameter **“CHAR”** = **“USER”**).

“Lo r”, **“Hi r”** - These parameters define the expansion of nominal range in percents. They determine the permissible range of input currents (Figure7.1).

The permissible range allow user to exceed the nominal range of input current. If input value is contained in the permissible range a proper result is displayed. If input current exceeds this range (defined by **“Lo r”** and **“Hi r”**), **“-Lo-”** or **“-Hi-”** warning is displayed depend on input current value.

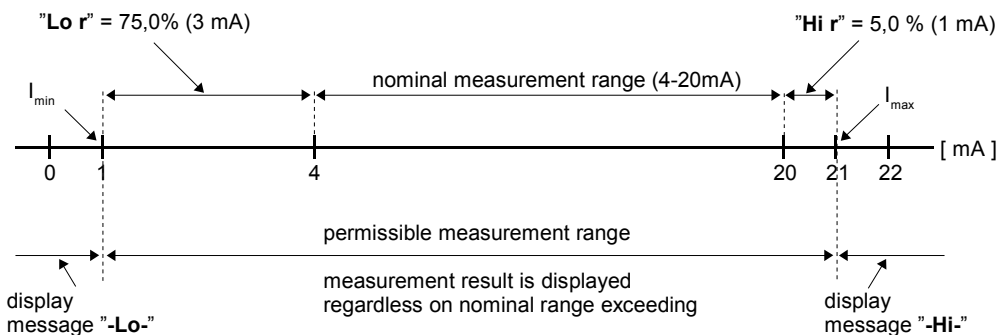

Figure 7.1 Example of definition of permissible range of input currents - **“Lo r”** and **“Hi r”** parameters (**“4-20”** mode)

The “**Lo r**” parameter is important if input is set to “**4-20**” mode only, and determines lower border of the permissible range. If input is set to “**0-20**” mode, lower border of the permissible range is always 0mA.
If input is set to “**4-20**” mode, the lower border is calculated due to expression:

$$I_{\min} = 4 \text{ mA} - 4 \text{ mA} \times \text{“Lo r”} \%$$

The “**Lo r**” value can be set from 0 to 99.9%.
Parameter “**Hi r**” determines the upper border of the permissible range accordingly to the expression (for both “**0-20**”i “**4-20**”modes):

$$I_{\max} = 20 \text{ mA} + 20 \text{ mA} \times \text{“Hi r”} \%$$

The value of “**Hi r**” can be set from 0 to 19.9%

In example no 1 of the **DISPLAY VALUES CALCULATION** paragraph the procedure of the permissible input range determining is presented in details.



If the measurement value do not exceeds **permissible measurement range** but displayed value exceeds range -999 ÷ 9999, the warning “**-Ov-**” is displayed rather than the calculated result.

7.3.3. “bri” parameter

This parameter allows user to set bright of the LED display, bright can be set to conventional values from 1 to 8.

7.3.4. “HOLd” menu

This menu contains parameters connected with peak detection function. See also full description of the peak detection function in paragraph : **DETECTION OF THE PEAK VALUES**

“**mode**” - the type of detected changes of the input signal, can be set to values

“**norm**” - peaks, peak and next drop of the input signal of value equal at least “**PEA**”,
“**inv**” - drops, drop and next peak of the input signal of value equal at least “**PEA**”,

“**PEA**” - minimal detected signal change classified as peak or drop (see Figure 6.3),

“**time**” - maximum time of displaying of the peak (drop) value, can be set from 1 to 19,9 sec, with 0,1 sec. resolution

“**HdiS**” - type of displayed values:

“**rREAL**” -current value is displayed,
“**HOLd**” - peak (drop) value is displayed,

“H r1”, “H r2” - LEDs/relay outputs operation mode:

- ”rEAL” - relay operates depend on the current value,
- ”HOLd” - relay operates depend on the peak (drop) value,

7.3.5. ”SECu” menu

This menu contains presets connected with availability of other parameters :

“AccE” - this option permits user (”on”) or prohibits (”oFF”) to modify the thresholds of the relays/LEDs without knowlborder about user password (see: **MEASUREMENT MODE**).

“Scod” - user password (4-digits number). If this parameter is set at value “0000”, user password is turned off.

If the user do not remember his password, the access to the menu is possible by the “one-use password”. To get this password please contact witch Marketing Division. Please set new user password immediately after use of the “one-use password” - see “Scod” parameter.



The “one-use password” can be used one time only, it is impossible to use it again! The “one-use password” can be restored by Service Division only.

7.3.6. ”rS” menu

This menu is connected with RS-485 interface, and sets his properties:

”Addr” - this parameter defines the address of the device, accordingly to Modbus protocol. It can be set in range from 0 to 199. If the value 0 is set then device, responds to frames with address 255 (FFh).

”bAud” - this parameter determines RS-485 interface baud rate. It can be set to one of 8 possible values: ”1.2”, ”2.4”, ”4.8”, ”9.6”, ”19.2”, ”38.4”, ”57.6”, ”115.2”, which respond to the baud rates of 1200, 2400, 4800, 9600, 19200, 38400, 57600 and 115200 bit/s respectively.

”mbAc” - this parameter sets the access to the configuration registers of the device. Possible values:

- ”on” - configuration registers can be set via RS-485 interface,
- ”oFF” - configuration registers can not be set via RS-485 interface.



The access to registers no 04h i 05h cant be denied by ”mbAc” parameter (see: **LIST OF REGISTERS**).

”mbtO” - this parameter defines maximal time (sec) between following frames received by the device. If the delay will be greater than the value of ”mbtO” parameter, the relays/LEDs which are controlled via RS-485 interface, will set to alert state (see “rEL1”, “rEL2” menu description). Parameter “mbtO” can be set to values from 0 to 99 seconds. The value 0 means that the time will be not controlled.

"rESP" - this parameter defines minimal (additional) delay between the Modbus message and the answer of the device (received and sent via RS-485 interface). This additional delay allows the device to work with poor RS-converters which do not works properly on baud rates higher than 19200. This poarameter can be set to one of values:

"Std" - answer as quick as possible, no additional delay

" 10c"

" 20c"

" 50c"

"100c"

"200c"

- answer delayed of 10, 20, 50, 100 of 200 chars respectively, where one character time depends on selected baud rate



In the most cases parameter **"rESP"** should be set to **"Std"** (no additional delay). Unfortunately for some third party RS-converters **"rESP"** should be adjusted experimentally. Table below contains most frequently used values.

<i>Parametr "bAud"</i>	<i>Parametr "rESP"</i>
"38.4"	" 10c"
"57.6"	" 20c"
"115.2"	" 50c"

Tab.7.1. Settings of "rESP" parameter

7.3.7. "SErv" menu

This menu contains the parameters for authorized service only. To enter this menu proper service password must be entered. Improper settings can causes of damage of the device.

7.4. MENU STRUCTURE

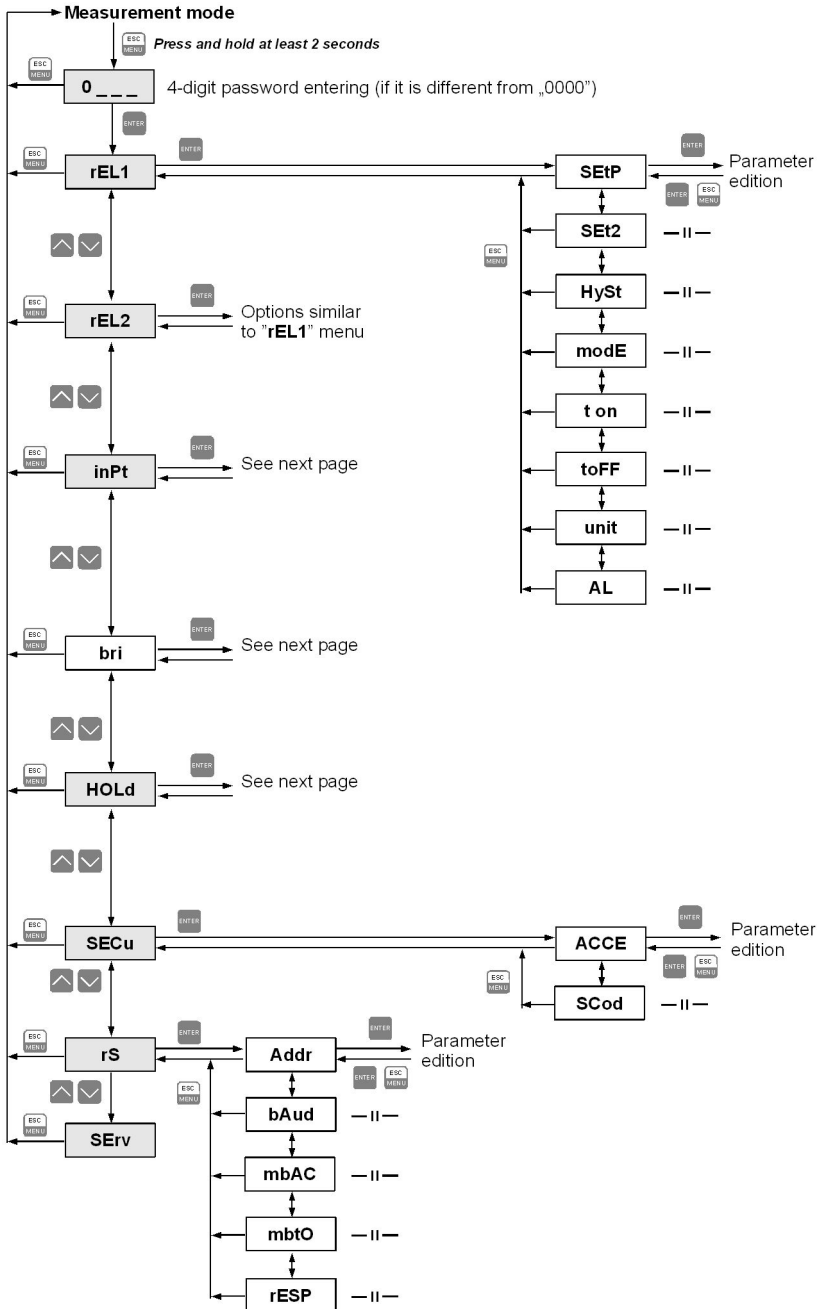

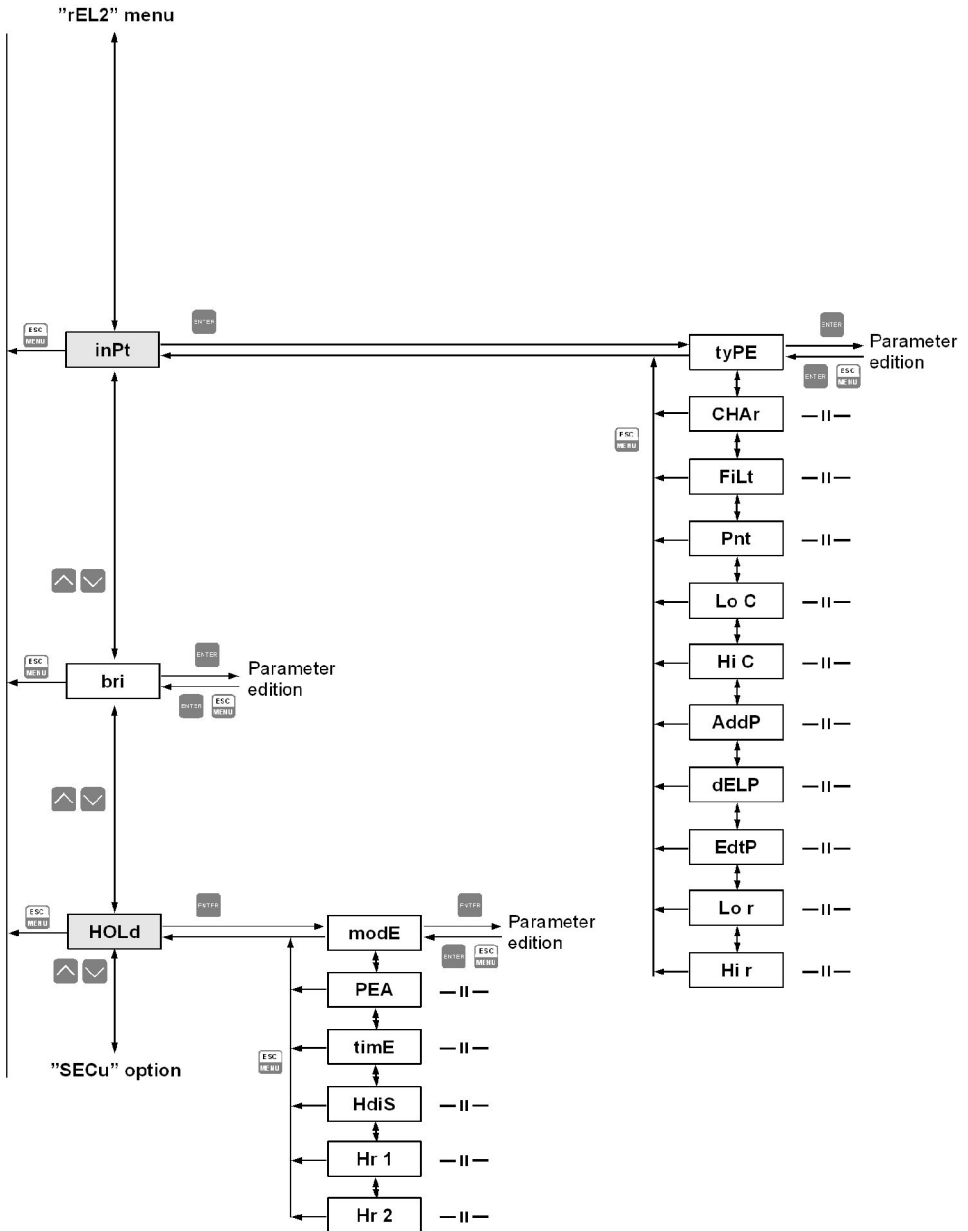

8. THE ALARM LED

The **ALARM LED** (AL) is turned on when input current is out of the permissible input range. See parameters: “**tyPE**”, “**Lo r**” and “**Hi r**” in paragraph „**InPt**” **menu**.

9. OVER-CURRENT PROTECTION

The input of the device is equipped with over-current protection circuit. This circuit protects the standard resistor to damage. Maximum input current is set to 40mA. When temperature of the standard resistor falls, the protection circuit will turn off himself automatically, and the device will measure the input current again. Due to thermal phenomenon in the standard resistor, precision of the measurement may be lower, during few minutes (up to the standard resistor temperature will falls to the environment temperature).

10. DISPLAYED VALUES CALCULATION

The first step to compute the result of measure is the calculation of the normalized result (it means result of 0-1 range). To do it, the begin of the input range (0 mA for 0-20mA range, and 4mA for 4-20mA range) must be subtracted from measured value. Next, received result must be divided by the width of the input range (it means 20mA for 0-20mA range, and 16mA for 4-20mA range). So normalized result can be expressed by expressions:

$$I_n = \frac{I_{inp.} - 4}{16} \quad \text{for } 4 \div 20 \text{ mA range}$$

$$I_n = \frac{I_{inp.}}{20} \quad \text{for } 0 \div 20 \text{ mA range}$$

where $I_{inp.}$ Means input current (in mA), and I_n - normalized result.



If measured value exceeds the nominal input range (0-20mA or 4-20mA), and do not exceed the permissible input range, then received normalized I_n result will exceed 0-1 range, e.g. input range 4-20 mA, input current = 3 mA – the normalized result is equal -0,0625, and for input current = 22 mA, the normalized result is equal 1,125. In such cases presented expressions are still correct.

10.1. ADDITIONAL CALCULATIONS (USED CONVERSION CHARACTERISTIC)

The manner of the additional computation of the displayed result depends on selected conversion characteristic. All presented charts are connected with the input range 4 - 20 mA.

10.1.1. Linear characteristic

The normalized result is converted by fixed coefficients determined by "Lo C" and "Hi C" parameters (when the normalized results is equal 0, then value "Lo C" is displayed, and when the normalized results is equal 1, then value "Hi C" is displayed). Expression presented below shows the manner of result calculation:

$$W = I_n \times ("Hi C" - "Lo C") + "Lo C",$$

where **W** means the displayed value.



The value of the "Lo C" parameter can be higher than the value of "Hi C" parameter. In such a case, for an increasing value of input current the displayed value decreases.

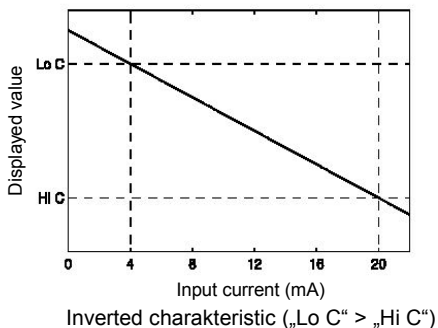
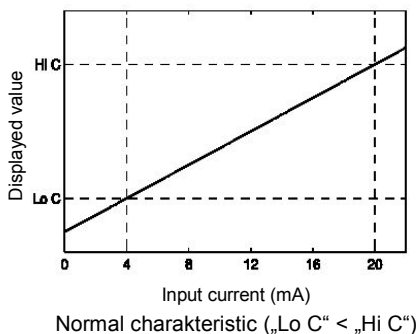

10.1.2. Square characteristic

The normalized result is squared and further conversion is done as for linear characteristic. Conversion is made accordingly with the expression:

$$W = I_n^2 \times ("Hi C" - "Lo C") + "Lo C",$$

where **W** means the displayed value.

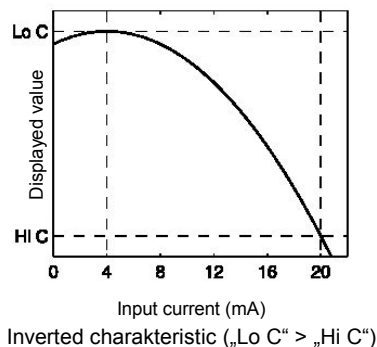
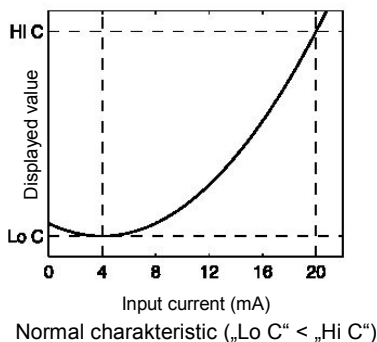

10.1.3. Square root characteristic

The normalized result is rooted and further conversion is done as for linear characteristic. Conversion is made accordingly with the expression:

$$W = \sqrt{I_n} \times ("Hi C" - "Lo C") + "Lo C",$$

where W means the displayed value.



Shown above expression is not valid when normalized result is negative. It is possible for 4-20 mode only. In this case ($I_n < 0$) the displayed result is equal **"Lo C"** (see graphs below).

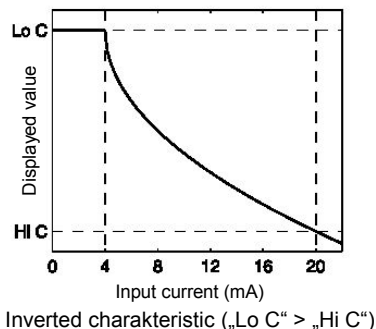
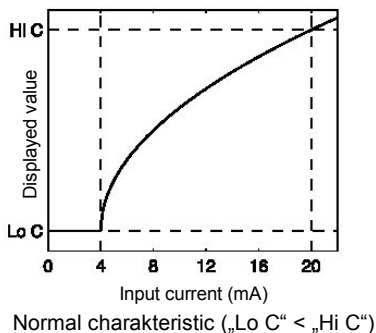

10.1.4. User defined characteristic

User defined characteristic is defined as set of X-Y points. Number of the points is variable and may be set from 2 to 20 points which make linear segments (see graph and see **Menu "inPt"**). Due to the normalized result I_n , the device computes specific segment, e.g. for characteristic from figure below, and $I_n = 0,65$ the segment between points X = "50.0." and X = "70.0." will be chosen.

Let's mark those points as PL (point low) i PH (point high) - in this example PL = "50.0." and PH = "70.0.", and the normalized result I_n for the point PL as I_p (in this example $I_p = I_n(PL) = 0,5$). The displayed result is calculated accordingly to the expression:

$$W = (I_n - I_p) \times \frac{[Y(PH) - Y(PL)]}{[X(PH) - X(PL)]} \times 100 + Y(PL)$$

where Y(PH), X(PH), Y(PL), X(PL) mean values of X and Y coordinates of PH i PL points.



If the normalized result exceeds the user defined characteristic values, then specific utmost segment, defined by two next points, is used for calculations. If characteristic from figure below is used, and if $I_n > 1$ then segment defined by points X(PL) = "90.0.", X(PH) = "100.0." will be used.

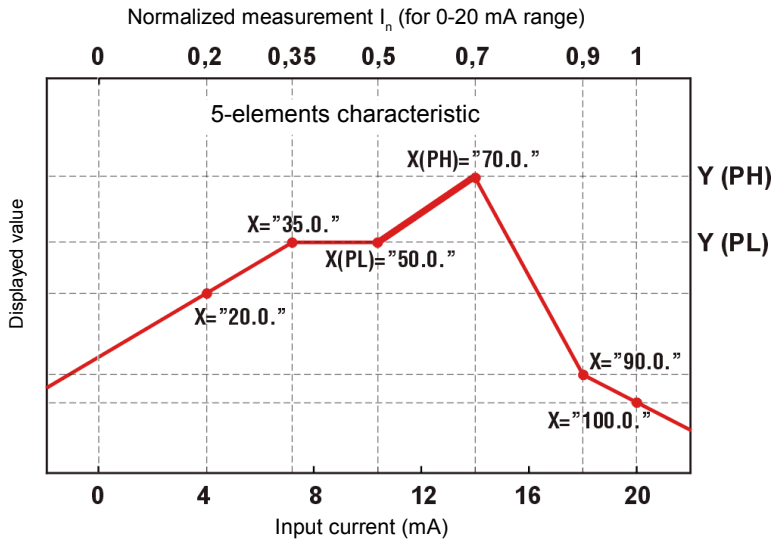

10.2. EXAMPLES OF CALCULATIONS

Example 1: Selection of the permissible input range ("4-20" mode)

If in "4-20" mode the user sets "Lo r" = 20,0% and "Hi r" = 10,0%, then permissible input currents range will be equal: 3,2 mA ÷ 22 mA. Lower border of the range is the result of calculations: 4 mA - 4 mA × 20%, and the higher : 20 mA + 20 mA × 10%.

Example 2: The normalized I_n result calculation

Let the input mode = 4-20 mA. The normalized I_n result is calculated accordingly to the expression on page 31, so if I_{in} = 10 mA then 10 mA - 4 mA = 6 mA, and this result should be divided by the width of input range (16 mA). Finally the normalized result: $I_n = 6/16 = 0,375$.

In case when input current exceeds nominal measurement range, calculations are similar. For example if input current is equal 2,5 mA then $I_n = (2,5 - 4)/16 \cong -0,0938$, and if input current is equal 20,5 mA then $I_n = (20,5 - 4)/16 \cong 1,0313$.

Example 3: The linear characteristic

Let the input mode = 4-20 mA, and parameters "Lo C" and "Hi C" equal to -300 and 1200 respectively. The calculations will be done for there different input currents from example 2.

a) $I_{in} = 10 \text{ mA}$ and $I_n = 0,375$

Accordingly to expression on page 32 for linear characteristic:

$0,375 \times [1200 - (-300)] \cong 562$ and next, the “**Lo C**” value is added to the result , so the displayed value:

$$W \cong 562 + (-300) = 262$$

b) $I_{in} = 2,5 \text{ mA}$ and $I_n = -0,0938$.

$$W \cong -441.$$

c) $I_{in} = 20,5 \text{ mA}$ and $I_n = 1,0313$.

$$W \cong 1247.$$

Example 4: The square characteristic

Let the input mode = 4-20 mA, and parameters “**Lo C**” and “**Hi C**” equal to -300 and 1200 respectively. The calculations will be done for there different input currents from example 2.

a) $I_{in} = 10 \text{ mA}$ and $I_n = 0,375$

Accordingly to expression on page 32 for linear characteristic: $(0,375)^2 \times [1200 - (-300)] \cong 211$. and next, the “**Lo C**” value is added to the result , so the displayed value:

$$W \cong 211 + (-300) = -89$$

b) $I_{in} = 2,5 \text{ mA}$ and $I_n = -0,0938$.

$$W \cong -287.$$

c) $I_{in} = 20,5 \text{ mA}$ and $I_n = 1,0313$.

$$W \cong 1295.$$

Example 5: The square root characteristic

Let the input mode = 4-20 mA, and parameters “**Lo C**” and “**Hi C**” equal to -300 and 1200 respectively. The calculations will be done for there different input currents from example 2.

a) $I_{in} = 10 \text{ mA}$ and $I_n = 0,375$

Accordingly to expression on page 33 for linear characteristic:

$$\text{sqrt}(0,375) \times [1200 - (-300)] \cong 919.$$

and next, the “**Lo C**” value is added to the result , so the displayed value:

$$W \cong 919 + (-300) = 619$$

b) $I_{in} = 2,5 \text{ mA}$ and $I_n = -0,0938$, normalized result is negative , so the displayed value is equal to “**Lo C**” parameter: $W \cong \text{“Lo C”} = -300$.

c) $I_{in} = 20,5 \text{ mA}$ and $I_n = 1,0313$.

$$W \cong 1223.$$

Example 6: The user defined characteristic

Let the input mode = 4-20 mA, and the user selected the 10 segment characteristic. To do this it is necessary to enter X and Y coordinates of 11 points (see **Menu "inPt"**). The calculations will be done for three different input currents from example 2, so in calculations some of the segments will be used only.

Let the following points will be given:

X1 = "00.0", Y1 = "-50.0",

X2 = "10.0", Y2 = "-30.0",

....

X6 = "30.0", Y6 = "30.0",

X7 = "40.0", Y7 = "80.0",

....

X10 = "90.0", Y10 = "900.0",

X11 = "100.0", Y11 = "820.0",

Additionally all other points must to be defined and stored in the device memory.

a) $I_n = 10$ mA and $I_p = 0,375$

The segment defined by X6 = "30.0" i X7 = "40.0" for this I_n will be selected. Accordingly to expressions given for user defined characteristic (see page 33) $X(PL) = 30$, $Y(PL) = 30$, $X(PH) = 40$, $Y(PH) = 80$ and $I_p = 0,3$, the displayed value :

$$W = (I_n - I_p) \times \frac{[Y(PH) - Y(PL)]}{[X(PH) - X(PL)]} \times 100 + Y(PL) =$$

$$= (0,375 - 0,3) \times \frac{[80 - 30]}{[40 - 30]} \times 100 + 30 \approx 67$$

b) $I_n = 2,5$ mA and $I_p = -0,0938$, because of the normalized I_n value is lower than 0, the segment defined by X1 and X2 will be selected. $X1(PL) = 0$, $Y1(PL) = -50$, $X2(PH) = 10$, $Y2(PH) = -30$ and $I_p = 0$. For these values the displayed value $W \approx -69$.

c) $I_n = 20,5$ mA and $I_p = 1,0313$, because of the normalized I_n value is higher than 1, the segment defined by X10 and X11 will be selected, and $X10(PL) = 90$, $Y10(PL) = 900$, $X11(PH) = 100$, $Y11(PH) = 820$ and $I_p = 0,9$ for these values the displayed value $W \approx 795$.

11. THE MODBUS PROTOCOL HANDLING

Transmission parameters: 1 start bit, 8 data bits, 1 stop bit, no parity control
 Baud rate: selectable from: 1200 to 115200 bits/second
 Transmission protocol: MODBUS RTU compatible

The device parameters and measurement result are available via RS-485 interface, as HOLDING-type registers of Modbus RTU protocol. The registers (or groups of the registers) can be read by 03h function, and wrote by 06h (single registers) or 10h (group of the registers) accordingly to Modbus RTU specification. Maximum group size for 03h and 10h functions can not exceeds 5 registers (for single frame).

The device interprets the broadcast messages, but then do not sends the answers.

11.1. LIST OF REGISTERS

Register	Write	Range	Register description
01h	No	-999 ÷ 9999	Current measurement value (no decimal point)
02h	No	0h, A0h, 60h	The status of the current measurement; 0h - data valid; A0h - top border of the measurement range is exceeded; 60h - bottom border of the measurement range is exceeded;
03h	Yes	0 ÷ 3	" Pnt " parameter in " InPt " menu (decimal point position) 0 - " 0"; 1 - " 0.0"; 2 - " 0.00"; 3 - "0.000"
04h	Yes	0 ÷ 31	State of the relays/LEDs and alarm LED (binary format) (1 - on, 0 - off): 00000000 000e00ba a - relay/LED R1; b - relay/LED R2; e - alarm LED; If written, only a , b bits are important (others are ignored) these bits allows user to control the relays/LEDs via RS-485 interface
06h	No	-999 ÷ 9999	Current peak (drop) value (no decimal point)
10h	Yes	0 ÷ 1	" tyPE " parameter in " InPt " menu (nominal input range). 0 - 0-20 mA range; 1 - 4-20 mA range
11h	Yes	0 ÷ 3	" CHAr " parameter in " InPt " menu (characteristic type) 0 - linear ; 1 - square; 2 - square root; 3 - user defined
12h	Yes	0 ÷ 5	" FiLt " parameter in " InPt " menu (measurement filtering rate)
13h	Yes	0 ÷ 3	" Pnt " parameter in " InPt " menu (the copy of 03h register, decimal point position) 0 - " 0"; 1 - " 0.0"; 2 - " 0.00"; 3 - "0.000"
14h	Yes	-999 ÷ 9999	" Lo C " parameter in " InPt " menu, no decimal point included
15h	Yes	-999 ÷ 9999	" Hi C " parameter in " InPt " menu, no decimal point included
16h	Yes	0 ÷ 999	" Lo r " parameter in " InPt " menu, in 0,1%
17h	Yes	0 ÷ 199	" Hi r " parameter in " InPt " menu, in 0,1%
20h ¹	Yes	0 ÷ 199	Device address
21h	No	21A0h	Device identification code (ID)

Register	Write	Range	Register description
22h ²	Yes	0 ÷ 7	“bAud” parameter in “rS” menu (baud rate); 0 - 1200 baud; 1 - 2400 baud; 2 - 4800 baud; 3 - 9600 baud; 4 - 19200 baud; 5 - 38400 baud; 6 - 57600 baud; 7 - 115200 baud
23h ³	Yes	0 ÷ 1	“mbAc” parameter in “rS” menu (permission to write registers via RS-485 interface); 0 - write denied ; 1 - write allowed
24h	Yes	0 ÷ 1	“AccE” parameter in “SECU” menu (permission to change of the thresholds without knowlborder of the user password); 0 - changes denied; 1 - changes allowed
25h	Yes	0 ÷ 5	“rESP” parameter in “rS” menu (additional response delay); 0 - no additional delay; 1 - “10c” option; 2 - “20c” option; 3 - “50c” option; 4 - “100c” option; 5 - “200c” option;
27h	Yes	0 ÷ 99	“mbtO” parameter in “rS” menu (maximum delay between received frames); 0 - no delay checking; 1 ÷ 99 - maximum delay expressed in seconds
2Dh	Yes	1 ÷ 8	Opcja “bri” (display brightness); 1 - the lowest brightness; 8 - the highest brightness
30h	Yes	-999 ÷ 9999	“SEtP” parameter in “rEL1” menu, no decimal point included
31h	Yes	-999 ÷ 999	“HySt” parameter in “rEL1” menu, no decimal point included
32h	Yes	0 ÷ 3	“modE” parameter in “rEL1” menu (operation mode of R1 relay/LED) 0 - no active; 1 - “on” mode; 2 - “oFF” mode; 3 - “in” mode; 4 - “out” mode; 5 - the relay/LED controlled via RS-485 interface
33h	Yes	0 ÷ 999	“t on” parameter in “rEL1” menu, expressed in tenth of seconds or tenth of minutes depend on “unit” parameter - register no. 35h)
34h	Yes	0 ÷ 999	“toFF” parameter in “rEL1” menu, expressed in tenth of seconds or tenth of minutes depend on “unit” parameter - register no. 35h)
35h	Yes	0 ÷ 1	“unit” parameter in “rEL1” menu (the time unit of R1 relay/LED); 0 - seconds; 1 - minutes
36h	Yes	0 ÷ 2	“AL” parameter in “rEL1” menu (the state of R1 relay/LED, while critical situation occurs); 0 - no changes; 1 - on; 2 - off
37h	Yes	-999 ÷ 9999	“SEt2” parameter in “rEL1” menu, no decimal point included
38h	Yes	-999 ÷ 9999	“SEtP” parameter in “rEL2” menu, no decimal point included
39h	Yes	-999 ÷ 999	“HySt” parameter in “rEL2” menu, no decimal point included
3Ah	Yes	0 ÷ 3	“modE” parameter in “rEL2” menu (operation mode of R2 relay/LED) 0 - no active; 1 - “on” mode; 2 - “oFF” mode; 3 - “in” mode; 4 - “out” mode; 5 - the relay/LED controlled via RS-485 interface
3Bh	Yes	0 ÷ 999	“t on” parameter in “rEL2” menu, expressed in tenth of seconds or tenth of minutes depend on “unit” parameter - register no. 3Dh)
3Ch	Yes	0 ÷ 999	“toFF” parameter in “rEL2” menu, expressed in tenth of seconds or tenth of minutes depend on “unit” parameter - register no. 3Dh)

Register	Write	Range	Register description
3Dh	Yes	0 ÷ 1	“ unit ” parameter in “ rEL2 ” menu (the time unit of R2 relay/LED); 0 - seconds; 1 - minutes
3Eh	Yes	0 ÷ 2	“ AL ” parameter in “ rEL2 ” menu (the state of R2 relay/LED, while critical situation occurs); 0 - no changes; 1 - on; 2 - off
3Fh	Yes	-999 ÷ 9999	“ SEt2 ” parameter in “ rEL2 ” menu, no decimal point included
50h	Yes	0 ÷ 1	“ modE ” parameter in “ HOLd ” menu (type of detected changes); 0 - peaks; 1 - drops
51h	Yes	0 ÷ 9999	“ PEA ” parameter in “ HOLd ” menu (minimum detectable change, no decimal point included)
52h	Yes	1 ÷ 199	“ time ” parameter in “ HOLd ” menu, maximum peaks' (or drops') display time expressed in seconds
53h	Yes	0 ÷ 1	“ HdiS ” parameter in “ HOLd ” menu (the type of values displayed on the display); 0 - current measurement value; 1 - peaks (or drops) values
54h	Yes	0 ÷ 1	“ H r1 ” parameter in “ HOLd ” menu (the control mode of relay R1 and LED R1) : 0 - control depends on current measurement values; 1 - control depends on peaks (or drops) values;
55h	Yes	0 ÷ 1	“ H r2 ” parameter in “ HOLd ” menu (the control mode of relay R2 and LED R2) : 0 - control depends on current measurement values; 1 - control depends on peaks (or drops) values;
70h ⁴	Yes	-999 ÷ 1999	The value of „ X ” coordinate of point no. 1 of the user defined characteristic, expressed in 0,1%
71h ⁴	Yes	-999 ÷ 9999	The value of „ Y ” coordinate of point no. 1 of the user defined characteristic, no decimal point included
72h ⁵ ÷ 95h ⁵			Further pairs of „ X ” - „ Y ” coordinates of points no. 2 ÷ 19 of the user defined characteristic
96h ⁴	Yes	-999 ÷ 1999	The value of „ X ” coordinate of point no. 20 of the user defined characteristic, expressed in 0,1%
97h ⁴	Yes	-999 ÷ 9999	The value of „ Y ” coordinate of point no. 20 of the user defined characteristic, no decimal point included

- 1 - after writing to register no 20h the device responds with an “old” address in the message.
- 2 - after writing to register no 22h the device responds with the new baud rate.
- 3 - the value of the “**mbAc**” parameter is also connected to write to this register, so it is possible to block a writes, but impossible to unblock writes via RS-485 interface, The unblocking of the writes is possible from menu level only.
- 4 - the pairs of „**X** - **Y**” coordinates may be defined for any free point. The pair is “free” (it means that particular point is not defined) if „**X**” coordinate of this point is equal 8000h. After writing both X and Y coordinate the point is defined and used in calculation of result. The coordinates of any point can be changed at any time.

11.2. TRANSMISION ERRORS DESCRIPTION

If an error occurs while write or read of single register, then the device sends an error code according to Modbus RTU specifications (example message no 5).

Error codes:

01h - illegal function (only functions 03h, 06h and 10h are available),

02h - illegal register address

03h - illegal data value

08h - no write permission (see: “**mbAc**” parameter)

A0h - exceed of upper border of input range

60h - exceed of lower border of input range

A0h and 60h codes can appear only during reg. 01h is reading by 03h function (read of a single register).

11.3. EXAMPLES OF QUERY/ANSWER FRAMES

1. Read of the displayed value (measurement), the device address = 01h:

ADDR	FUNC	REG H,L		COUNT H,L		CRC L,H	
01	03	00	01	00	01	D5	CA

a) The answer (we assume that input current is not out of range):

ADDR	FUNC	BYTE C	DATA H,L		CRC L,H	
01	03	02	00	FF	F8	04

DATA H, L - displayed value = 255, no decimal point. Decimal point position can be readed from reg. 03h.

b) The answer (if an error occur):

ADDR	FUNC	ERROR	CRC L,H	
01	83	60	41	18

ERROR - error code = 60h, bottom border of the measurement range is exceeded

2. Read of ID code

ADDR	FUNC	REG H,L		COUNT H,L		CRC L,H	
01	03	00	21	00	01	D4	00

The answer:

ADDR	FUNC	BYTE C	DATA H,L		CRC L,H	
01	03	02	21	A0	A0	6C

DATA - identification code (21A0h)

3. Change of the device address from 1 to 2 (write to reg. 20h)

ADDR	FUNC	REG H,L		DATA H,L		CRC L,H	
01	06	00	20	00	02	09	C1

DATA H - 0

DATA L - new device address (2)

The answer (the same as the message):

ADDR	FUNC	REG H,L		DATA H,L		CRC L,H	
01	06	00	20	00	02	09	C1

4. Change of baud rate of all devices connected to the net (BROADCAST message).

ADDR	FUNC	REG H,L		COUNT H,L		CRC L,H	
00	06	00	22	00	04	29	D2

DATA H - 0

DATA L - 4, new baud rate 19200 baud



Device do not reply to BROADCAST-type messages.

5. Read of the registers 1, 2 and 3 in one message (example of writing a number of registries in one frame):

ADDR	FUNC	REG H,L		COUNT H,L		CRC L,H	
01	03	00	01	00	03	54	0B

COUNT L - the count of being readed registers (max. 5)

The answer:

ADDR	FUNC	BYTE C	DATA H1,L1		DATA H2,L2		DATA H3,L3		CRC L,H	
01	03	06	00	0A	00	00	00	01	78	B4

DATA H1, L1 - reg. 01h (10 - displayed value "1.0"),,

DATA H2, L2 - reg. 02h (0 - no errors),,

DATA H3, L3 - reg. 03h (1 - decimal point position " 0.0").



There is no full implementation of the Modbus Protocol in the device. The functions presented above are available only.

12. DEFAULT AND USER'S SETTINGS LIST

<i>Parameter</i>	<i>Description</i>	<i>Default value</i>	<i>User's value</i>	<i>Desc. page</i>
Parameters of relay/LED R1 operation ("rEL1" menu)				
SEtP	Relay/LED R1 threshold	20.0		21
SEt2	Relay/LED R1 second threshold	30.0		21
HYSst	Hysteresis of relay/LED R1	0.0		21
modE	Operation mode of relay/LED R1	in		22
t on	Turn on delay of relay/LED R1	0.0		22
toFF	Turn off delay of relay/LED R1	0.0		22
unit	Unit of "t on", "toFF" parameters of relay/LED R1	SEC		23
AL	Reaction for critical situation of relay/LED R1	oFF		23
Parameters of relay/LED R2 operation ("rEL2" menu)				
SEtP	Relay/LED R2 threshold	40.0		21
SEt2	Relay/LED R2 second threshold	50.0		21
HYSst	Hysteresis of relay/LED R2	0.0		21
ModE	Operation mode of relay/LED R2	in		22
t on	Turn on delay of relay/LED R2	0.0		22
toFF	Turn off delay of relay/LED R2	0.0		22
unit	Unit of "t on", "toFF" parameters of relay/LED R2	SEC		23
AL	Reaction for critical situation of relay/LED R2	oFF		23
Configuration of measurement input ("inPt" menu)				
tYPE	Input mode	„0-20"		23
CHAr	Conversion characteristic mode	Lin		23
FiLt	Filtering ratio	0		24

Parameter	Description	Default value	User's value	Desc. page
Pnt	Decimal point position	0.0		24
Lo C	Minimum displayed value (for nominal range)	000.0		24
Hi C	Maximum displayed value (for nominal range)	200.0		24
Lo r	Extension of the bottom of the nominal input range	5.0 (%)		25
Hi r	Extension of the top of the nominal input range	5.0 (%)		25
Display parameters				
bri	Display brightness	bri6		26
Configuration of peaks detection function ("HOLD" menu)				
modE	Kind of detected changes	norm		26
PEA	Minimum detected change	0.0		26
timE	Maximum time of peak displaying	0.0		26
HdiS	The type of displayed value	HOLd		26
H r1	Source of relay R1, and LED R1 control	rEAL		27
H r2	Source of relay R2, and LED R2 control	rEAL		27
Settings of access to the configuration parameters ("SECu" menu)				
AccE	Permission to changes of relays/LED thresholds without of the user password knowledge	on		27
RS 485 interface configuration ("rS" menu)				
Addr	Device address	0		27
bAud	Baud rate	9.6		27
mbAc	Blocking of access to the configuration registers	on		27
mbtO	Maximum delay between received messages	0		27
rESP	Additional delay of answer transmission	Std		28



APLISENS Sp. z o.o. , ul. Morelowa 7

PL - 03-192 Warszawa, Poland

tel.: (+48 22) 814-07-77, fax: (+48 22) 814-07-78

<http://www.aplisens.com.pl>, e-mail: aplisens@aplisens.pl